



Factors affecting the acquisition of training knowledge by Vietnamese university lecturers through International joint training programs at the university level

Ai Huu Tran

Lecturer, Faculty of Economics, Van Hien University, Ho Chi Minh City, Vietnam

Abstract

Learning about the factors affecting the acceptance of training knowledge by lecturers through international training programs will shed light on how teachers can receive the most knowledge. Knowledge acquisition will be most effective when the stakeholders increase the factors that have a positive influence and minimize the factors that have a negative effect on the knowledge acquisition of the lecturers. When the majority of lecturers in the international joint training program receive effective international training, knowledge, and knowledge will be spread throughout the university, progressing to upgrading the general level of teaching capacity of the lecturer's school. The quality of training of the school has since been enhanced, both meeting the aspiration for innovation in the education of the society and meeting the needs of international education integration of Vietnam's higher education.

Theoretically, research on knowledge acquired in international cooperation in Vietnam and in the world has focused on the reception at organizational levels, not on individual learning. Some test results on the influence of individual factors on knowledge acquisition are inconsistent, suggesting the possibility of a moderating variable for that effect. In addition, previous studies examined the impact of two groups of individual and social factors on knowledge acquisition separately, without taking into account the regulatory relationship between these two groups of factors. Research complements that theoretical gap.

Keywords: Knowledge acquisition, international training links, educational integration, Vietnam

Introduction

Learning about the factors affecting the reception of training, and knowledge of the lecturers through the program will shed light on how to make the lecturers receive the most knowledge. Universities/international integration programs will be able to facilitate the maximum effective reception of such knowledge by enhancing the factors that have a positive influence and minimizing the factors that have a negative impact on the teacher's acceptance of knowledge to the extent that the circumstances allow. When the majority of lecturers in the international training program receive effective international training and knowledge, they will create a spillover effect in the school, progressing to upgrading the general level of teaching capacity taught by school teachers. The quality of the school's training has since been enhanced, both meeting society's educational innovation aspirations and meeting the needs of international education integration of Vietnamese higher education.

In terms of theory, knowledge transfer, reception and management is an area that has received research attention from scholars. Many theories have been put forward in this field, but international and Vietnamese empirical studies focus on knowledge acquisition and management through cooperative relationships between enterprises, and on knowledge management. The context of cooperation between universities has not received much attention.

In addition, research on knowledge acquired in international cooperation in Vietnam and around the world has focused on the reception at the organizational level, not on individual learning, nor on individual learning mentions a lot about the role of the individual in the acquisition of knowledge. Easterby-Smith *et al* (2009) argue that the individual is the organization's knowledge repository and part of the knowledge transfer mechanism. Nonaka (1994)^[22] asserts that knowledge cannot be created without individuals, and emphasizes that organizational knowledge is derived from individuals' commitment to receive knowledge. Even so, studies have not sufficiently reasoned about individual-level influencing factors in knowledge transfer studies (Fey *et al.*, 2014)^[19]. Many researchers have argued that the shortcoming of the knowledge-based perspective is that it places too much emphasis on collective factors and ignores individual-level variables. Therefore, integrating micro-platforms in the organizational learning process is a potential topic to enrich the theory of knowledge creation (Foss, 2009)^[10].

In practical terms, the study of the factors affecting the acquisition of training knowledge by lecturers through the international training joint program will contribute to the renovation and international integration of the university. higher education in Vietnam by helping to identify the factors that need to be focused on improving or overcoming so that lecturers can learn the most from training practices,

knowledge and skills from advanced education systems in the world, thereby applying them in university teaching.

Theoretical basis

1. Knowledge concept

The concept of knowledge has been of interest since ancient times, and epistemology is a philosophical field discussed by ancient Western philosophers. From a philosophical and epistemological point of view, the definition of knowledge is divided into two schools: idealist and empiricist. Plato, Descartes, Kant, Hegel, Husserl, Heidegger, and Sartre are typical scholars of the idealistic school (Jashapara, 2011)^[13], which considers knowledge as an entity of the mind, derived from Plato's concept: knowledge Consciousness is "justified true belief" (Kakabadse *et al.*, 2003)^[14]. The empiricist school of Aristotle, Locke, Hume, Pierce, James, Dewey and Wittgenstein associates knowledge with action, arguing that knowledge comes from the experience of the senses and is limited by experience (Jashapara, 2011)^[13].

Although there is not really a consensus on the view of knowledge (Jashapara, 2011^[13], Tzortzaki and Mihiotis, 2014^[36]), modern views are developed based on both these schools. Knowledge, according to Nonaka (1994)^[22], involves the dynamism of each person when demonstrating their belief in the quest for truth, which is "information, technology, know-how, skill" (Grant, 1996)^[11]. or "information valuable for action" (O'Dell and Grayson, 1998)^[24].

Knowledge is a rationally justified personal belief, through a combination of personal experiences, values and characteristics, and interactions with others. These definitely considered knowledge to be developed from the continual accumulation and verification of information, thus being knowledge used for decision-making and action.

2. Knowledge classification

Knowledge is divided into many types based on different aspects as follows: (1) according to the explicit nature: there are two types of hidden knowledge (tacit) and explicit knowledge (explicit); (2) according to the subject of knowledge: there are 2 types: individual knowledge (individual) and collective knowledge (collective); (3) according to the nature and expression of knowledge: there are 3 types of knowledge: descriptive knowledge (know-what), know-how knowledge and understanding knowledge (know-why). There is no clear boundary between explicit and implicit knowledge (Nonaka and Krogh, 2009)^[23]. They are at either end of an axis. Almost all knowledge has a level of implicit and explicit (Alavi and Leidner, 2001)^[2].

Some authors argue that collective knowledge actually does not exist, or at least is very faint, because "the learning process takes place in the mind of the individual" (Simon, 1991), and this argument was supported by Grant (1996)^[11] when he argued that knowledge creation is an individual activity, while the collective, or organization, has the main task of applying the available knowledge of individuals to

provide wealth and service.

Descriptive knowledge and know-how were introduced by Ryle (1949)^[31], and then Anderson (1981) further developed into two groups: descriptive knowledge and know-how. Following this classification, a number of other authors (Garud, 1997) have developed and supplemented with knowledge-know-how.

There is currently no specific research on awareness of training programs. Training knowledge is related to teaching and learning expertise, student assessment, and management knowledge is related to ensuring the regular operation of the university training program. Higher education is a special service because the ultimate perceived value, called "customer value" (Dorri *et al.*, 2012)^[6], is contributed by both the service provider and the customer row. Therefore, there are many value chain models developed specifically for higher education, researched and developed by scholars Van de Merwe and Cronje (2004)^[37], Pathak and Pathak (2010)^[28].

3. Receiving knowledge

An individual's knowledge acquisition is the search, collection, and acquisition of new knowledge (Esmaelinezhad and Afrazeh, 2018^[8], Kim and Lee, 2010).^[16] According to this definition, knowledge acquisition is similar to learning. Jashapara (2011)^[13] reviews two schools of cognitive and behavioral psychology, thereby explaining that: in terms of cognition, learning takes place when there is a change in the state of knowledge, and in terms of behavior, learning is a change in responsiveness.

4. Compare knowledge and understanding

Although frequently used in close contexts and representing the same topic of knowledge and learning, "knowledge" and "knowing" are clearly distinguished scholars. Knowledge is an object, possibly a commodity, while knowing is an action. Knowledge is "knowledge in action" (Nissen (2006), a social achievement that occurs when the subject engages with the world through practice (Orlikowski, 2002

5. Knowledge of training

There is currently no research specifically on knowledge of training programs. This thesis divides knowledge in the international joint training program into two areas: training knowledge and management knowledge. Training knowledge is related to teaching and learning expertise, student assessment, and management knowledge is related to ensuring the regular operation of the university training program.

The author uses the value chain model of Sison and Pablo (2000)^[32] for universities. This is the value chain built when scholars develop the E-College system. This value chain is very useful in analyzing training services provided to students and also as a tool for designing management systems.

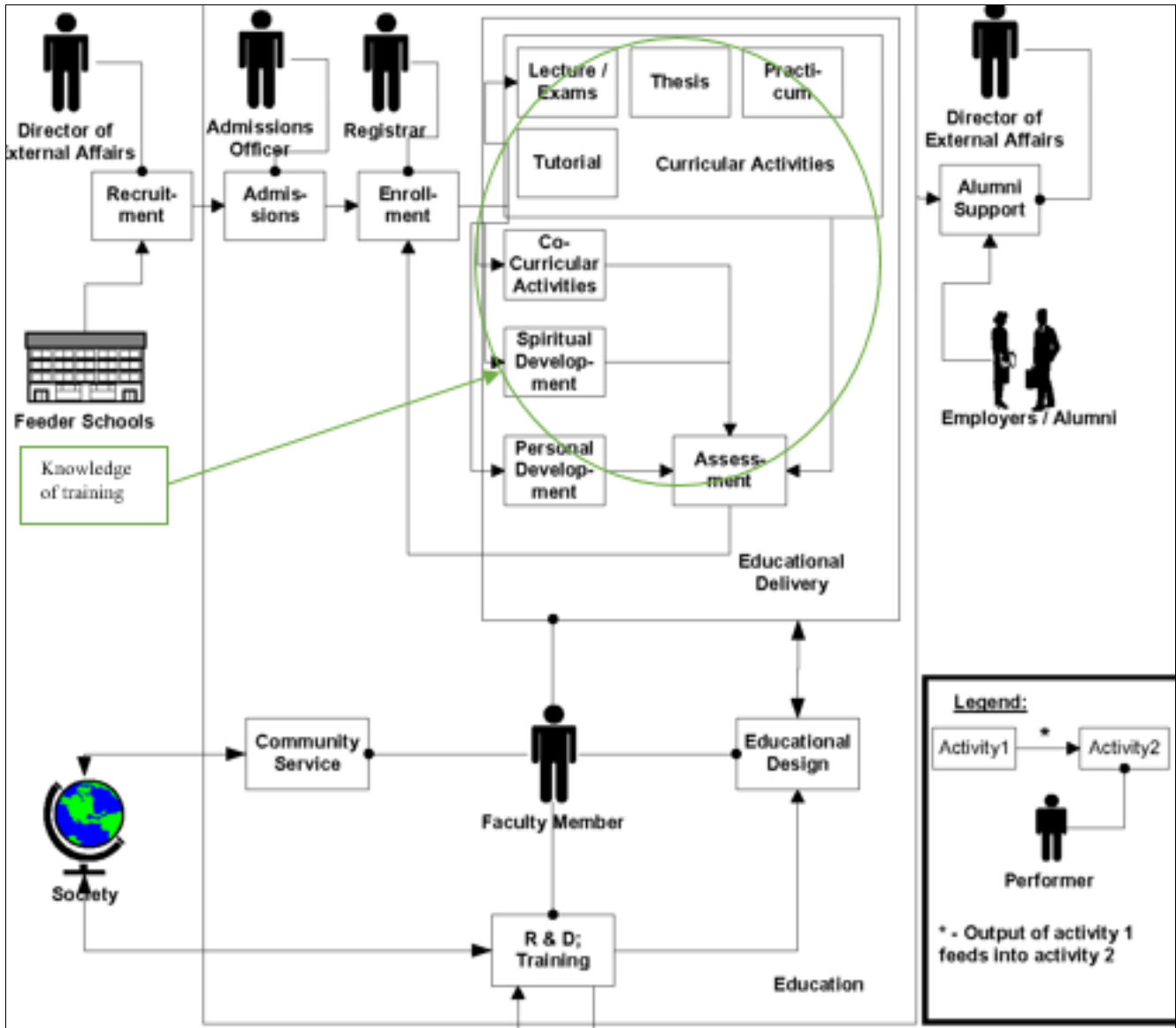

(Source: Vera and Crossan, 2005) [38]

Fig 1: Relationship between learning, knowledge and understanding

Research overview of factors affecting the acquisition of personal knowledge

1. There have been many theoretical and empirical studies on knowledge transfer and acquisition between two organizations in strategic alliances, and internal knowledge transfer between groups and departments. But among them, there are very few studies on the factors affecting the knowledge acquired at the individual level in the contexts of international association and cooperation. Currently, there are very few studies on knowledge acquisition in international joint training programs in Vietnam and around the world. The most relevant studies include those of Sustrino and Pillay (2015). Some studies use other theoretical classifications (Dao and Nguyen, 2016 [5], Ko *et al.*, 2005) and add knowledge characteristics to the influencing factors (Dao and Nguyen, 2016) [5]. There are two types of contexts for studies of individual knowledge acquisition: (i): Internal knowledge acquisition: research on knowledge transfer and

reception among employees in an organization/project (Esmaeelinezhad and Afraze, 2018) [8].

2. Receiving knowledge from outside through international cooperation, association, joint venture, or consulting project with knowledge givers and receivers belonging to two different organizations (Dao and Nguyen, 2016 [5], Ojo and Raman, 2017) [26].

1. Research theoretical frameworks are used to group factors

In the study of personal knowledge transfer between IT consultants and customers, Ko *et al* (2005) [17] use the research framework of Szulanski (1996) [34] but re-divide the factors into three groups' knowledge factors, communication factors and motivational factors. Furthermore, the study of Ko *et al.*, (2005) [17] on knowledge transfer from 38 technology consultants to 80 client organizations implementing projects in the US confirms the dependence on knowledge transfer. on the following factors: the capacity to absorb knowledge, share knowledge, relationship internal motivations of recipients and donors, and the reliability of information sources.

2. Personal factors affecting knowledge acquisition

The theory of knowledge absorptive capacity was first laid by Cohen and Levinthal (1990) [3], and later developed by scholars, and extended to knowledge acquisition at both the organizational and individual levels.

The school of personality traits affecting learning is explored by scholars Esmaeelinezhad and Afrazeh (2018) [8]. On the basis of Ajzen's (1991) [1] theory of planned behavior argue that five traits in the personality model, including openness, conscientiousness, extraversion, and sociability, and sensitivity (Costa and McCrae, 1992) [4] have an impact on individuals' knowledge management behavior, including knowledge acquisition behavior.

3. Social factors affecting knowledge acquisition

Social factors are considered from different perspectives in the studies of Ko *et al* (2005) [17], Kim and Lee (2010) [16],

May *et al* (2011), and Kankanhalli *et al* (2012) [15]. Sutrisno and Pillay (2015) give an interesting result. It is the most effective activity in knowledge transfer between the two schools is the process of mapping the training program. In this activity, officials from both sides interact regularly, and Indonesian officials must constantly update information about changes in Australia's training program. This makes them learn more about building training programs.

The reciprocal interaction on an issue helped Indonesian officials to acquire tacit and explicit knowledge of training curriculum development. However, the dissemination of knowledge to the training departments in the university is limited due to internal communication problems, so the new knowledge is only stored and used in the unit with the affiliate program international training (Sutrisno and Pillay, 2015).

Table 1: Summary of some studies on factors affecting the acquisition of personal knowledge

Author	Method	Theme and Background	Theoretical basis	The influencing factor is confirmed through the test	Contribute
Kankanhalli <i>et al.</i> , (2012) [15]	Quantitative	Learning effectiveness of 164 students in a research project on IT at a university	Salomon and Perkins (1998): personal and social aspects of learning; Lonka <i>et al</i> (1996): psychological activity when learning; Nahapiet and Ghoshal (1998), Lin (2001): the social capital of the organization	Ability to absorb knowledge; The proactive search for knowledge; Not applicable (not quantitatively tested); Learning orientation Share knowledge Share practices;	Affirming the influence of individual factors and social factors on knowledge acquisition. Lonka <i>et al</i> (1996): psychological activity when learning; Testing the interaction between individual factors and society in the relationship with learning effectiveness.
Sutrisno and Pillay (2015)	Qualitative	Knowledge transfer in the international joint training program between the Australian University and the University of Indonesia	Easterby-Smith <i>et al</i> (2008) [7]: knowledge transfer between two organizations;	Not applicable (not quantitatively tested)	Research framework with factors affecting knowledge transfer: intentions of two partners, number of students entering the joint program, mutually beneficial relationship, communication channel, stage of contract work.
Dao and Nguyen (2016) [5]	Quantitative & Qualitative	Receive knowledge of 109 Vietnamese managers at multinational enterprises in Vietnam	Szulanski (1996) [34]: knowledge transfer depends on characteristics of the giver, receiver, knowledge and relationship; Cohen and Levinthal (1990) [3],	Skills to work in a multicultural environment of foreign experts and Vietnamese officials	Compare and survey two-way giver and receiver
Ojo and Raman (2017) [26]	Quantitative	Knowledge acquisition capacity of 205 ICT project team members at 62 joint ventures in Malaysia	Cohen and Levinthal (1990) [3], Zahra and George (2002) [40]: capacity to absorb knowledge; Nonaka and Takeuchi (1995): knowledge creation theory	Staff willing to learn Experience of experts; Orientation of learning goals Cognitive needs	Affirming the influence of individual factors on knowledge acquisition in international cooperation; Consider the influence on the process of knowledge acquisition in two stages
Esmaeel inezhad, Afrazeh (2018)	Quantitative	Knowledge management behavior of 221 employees at 5 Iranian companies	Ajzen (1991) [1]: theory of planned behavior	Openness Devotion	Affirming the influence of personal characteristics of 5 major characteristics on knowledge acquisition

When there are not many studies on knowledge acquisition in the cooperative relationship between two universities, similar research in the business context can be used as a reference, but the knowledge acquisition model will need to be tested redefining, although the two contexts are the same "child" entity established by partners who are "parent" organizations in foreign and Vietnamese countries, to provide a product or service to the market.

While the parent companies have limited responsibility for the operation and quality of the joint venture's products, in the international joint training program the degree-granting institution is solely responsible for the quality of the

diploma, or more broadly, the quality of training. Because the international joint training program has no legal entity, the Vietnamese university or the foreign university, or both parties, shall grant the same degree and bear respective responsibilities.

The affiliate program is considered by both the Vietnamese side and the foreign side as their own, belongs to them and therefore has a higher attachment to the "parent" schools than a joint venture with the parent companies. This difference in attachment can affect the knowledge recipient's consciousness and level of learning, as well as the donor's intention and level of knowledge delivery.

Models	Funding	Participation of Vietnamese partners	Participation of foreign partners	Goals of Vietnamese partners	Degree
Use of funding (Before 2000)	Sponsorship from a third party	Receive funding. Provide training venue Logistics; Participate in the selection of students	Provide training program Provide trainers; Degree in quality control	Training the team, the program was implemented on schedule and effectively	Foreign partner

Training cooperation in the country, foreign universities play a key role (1995 - present)	Students contribute one or all	Like the model above and: Contribution of VN teaching assistants Contribution of VN lecturers in some subjects; Can work with foreign partners to adjust the teaching content to suit the VN situation	Like the model above and: Training for Vietnamese teachers and teaching assistants; Can work with Vietnamese partners to adjust teaching content to suit Vietnamese circumstances	Improve the training capacity of the school (lecturers and facilities); Train high-quality human resources for the country; Attract many students to fund ya8ng	Foreign partner or parallel
Franchising (2005 – present)	Student	Like the model above and: Contribution of Vietnamese teaching assistants Contribution of Vietnamese lecturers in some subjects; Can work with foreign partners to adjust the teaching content to suit the Vietnamese situation	As the model above, the number of trainers provided is reduced or may not be provided	Strengthen the training capacity of the school; Meeting the demand for access to international education for the majority; Scaling up cooperation and training	Foreign partner

(Source: Phan Thuy Chi and Le Thi Huong Lan, 2017) [29]

Research model

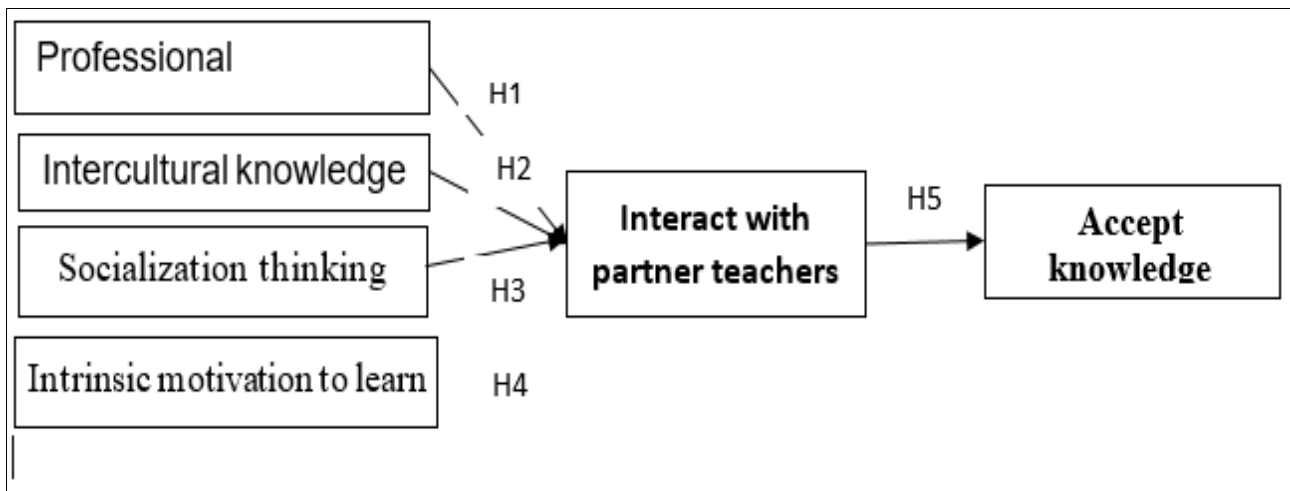

Fig 2: Research model

Hypotheses based on the theory of knowledge absorption capacity

The influence of professional knowledge factors on knowledge acquisition

Pre-existing knowledge (Cohen and Levinthal, 1990) [3], or abilities (Minbaeva *et al.*, 2003) [20] of an individual includes that individual's knowledge, abilities, skills, and experience (Yildiz *et al.*, 2019) [39]. Learning is a cumulative process, so learning in the past affects your ability to learn in the future.

Hypothesis

H1: Professional knowledge of Vietnamese lecturers has a positive influence on their acquisition of training knowledge

The influence of intercultural knowledge factors on knowledge acquisition

The intercultural knowledge base is not mentioned much in theories of knowledge absorption capacity, but is recognized by some scholars (Dao and Nguyen, 2016 [5], Park and Choi, 2014 [27], Yildiz *et al.*, 2019) [39] when researching on knowledge acquisition, knowledge absorption capacity in the context of multinational companies or international joint ventures. Makino and Delios, cited by (Park, 2010), argue that the international experience of domestic workers makes recognizing and accessing new knowledge more effective, thereby making an important contribution to learning effectiveness.

Hypothesis H2: The intercultural knowledge of Vietnamese lecturers has a positive influence on their acquisition of training knowledge.

The influence of intrinsic learning, motivation factors for knowledge acquisition

According to Minbaeva *et al.*, (2003) [20] and Kim *et al.*, (2010) [16], the intensity of both the cognitive and behavioral efforts of a person is determined by the motivation to learn. Motivation to learn is the willingness and motivation of an individual to receive knowledge. Although the ability to learn is high, if the motivation to learn is low, the acquisition of knowledge will be very limited (Minbaeva *et al.*, 2003) [20]. The capacity to absorb knowledge is integrated over time as individuals practice professional practices, and from self-study, research and prior accumulation of employees (Ojo and Raman, 2017) [26].

Hypothesis H3: The intrinsic learning motivation of Vietnamese lecturers has a positive influence on their knowledge acquisition about training.

The influence of socialization thinking factors on knowledge acquisition

The process of value recognition and knowledge assimilation involves making connections between new knowledge and cognitive structures (Cohen and Levinthal, 1990) [3], which is influenced by thinking style. Each person's thinking style reflects how they process

information and make decisions (Lowik *et al.*, 2017) [19]. There are two main thinking styles, the associative cognitive style and the association cognitive style. Intrinsic motivation to learn manifests as an individual learns because he or she enjoys learning. The motivation to learn is also reflected in efforts (Minbaeva *et al.*, 2003) [20].

Hypothesis H4: The socialization mindset of Vietnamese lecturers has a positive impact on their acquisition of training knowledge.

The influence of the interaction factor of Vietnamese lecturers with partner lecturers

Interactions of Vietnamese lecturers with partner lecturers is the three starting points for international training knowledge received by Vietnamese lecturers. Nonaka's theory two decades ago suggested that face-to-face interaction is the setting of three initiations since face-to-face interaction is the only tool for capturing the full spectrum of psychophysiological sensations and responses – an important factor in sharing tacit knowledge (Nonaka *et al.*, 2000). The author uses Lin's (2005) [18] interaction scale and Napier's (2005) [21] criteria on the diversity of interactive channels and communication levels to build a scale of the interaction of Vietnamese lecturers with partners.

Hypothesis H5: The interaction of Vietnamese lecturers with their partner trainers has a positive impact on their acquisition of training knowledge.

Scale for knowledge acquisition

Previous scholars (Dao and Nguyen, 2016 [5], Esmaeelinezhad and Afrazeh, 2018, Kankanhalli *et al.*, 2012 [15], Kim and Lee, 2010) [16] have built a set of scales for personal knowledge acquisition. Dao and Nguyen (2016) [5] measure understanding of technical and management issues

and processes. Esmaeelinezhad and Afrazeh (2018) [8] and Kim and Lee (2010) [16] share the same scale of frequency of knowledge search and acquisition. Kankanhalli *et al.*, (2012) [15] measure improvement in knowledge, thinking skills and connection.

Research Methods

Qualitative research has the goal of finding new factors, checking and screening independent variables in the preliminary model, preliminary determining the relationship between independent and dependent variables, and checking the scale. Qualitative research was carried out by in-depth interviews with lecturers of two different international joint training programs about their partners and majors, which is the Bachelor of Business Administration program in cooperation between the National University of Economics and Business with the University of Sunderland and the Bachelor of Banking and Finance program in cooperation between the National Economics University and the University of the West of England. Primary information is collected through in-depth interviews with lecturers about their knowledge acquisition. The total number of interviewees is 8 lecturers, divided equally between the two programs.

The qualitative study was carried out from May to August 2022. The results of the qualitative study are some qualitative evidence of the research model and the validation of the scale.

Quantitative research has the goal of re-testing the proposed model after adjusting it through qualitative research. Quantitative research was conducted with 148 lecturers to test the research model, carried out from September to December 2022.

Table 3: Formal scale for dependent variable Knowledge acquisition

No	Factors	Scales	Mean	Standard deviation
1	Knowledge reception Alpha = 0.825	Descriptive knowledge of course content	4.17	0.643
2		Knowledge and secrets about subject content	3.67	0.753
3		Knowledge and understanding of course content	3.54	0.844
4		Descriptive knowledge of teaching methods	3.54	0.971
5		Know-how about teaching methods	3.45	0.966
6		Knowledge of teaching methods	3.43	0.974
7		Descriptive knowledge of assessment methods	3.95	0.820
8		Know-how about assessment methods	4.01	0.854

(Source: Compiled by the authors)

Table 4: Cronbach's Alpha test results before EFA analysis

No	Scales	Number of observed variables	Cronbach's Alpha	Cronbach's Alpha if Item Deleted
1	Professional knowledge (PK)	5	0.882	0.553
2	Intercultural knowledge (IK)	5	0.894	0.646
3	Socialization thinking (ST)	5	0.845	0.556
4	Intrinsic motivation to learn (IML)	4	0.817	0.533
5	Interact with partner teachers (IPT)	5	0.843	0.621
6	Accept knowledge (AK)	4	0.814	0.611

(Source: Compiled by the authors)

Evaluation of the scale: First, the scales will be preliminarily evaluated through two methods: Cronbach's Alpha reliability coefficient and the exploratory factor analysis (EFA). Next, the scales were tested by means of confirmatory factor analysis (CFA).

Theoretical model testing: Along with confirmatory factor analysis (CFA), model testing has been carried out through AMOS 23 linear structural analysis software.

In the multiple regression model, we have the additional hypothesis that the independent variables are not completely correlated with each other. Thus, when estimating the multiple regression model, this assumption must be tested by testing the phenomenon of multicollinearity.

We use the VIF index (the Variance Inflation Factor). Usually, if the VIF of a certain variable is >2 , then this variable has almost no explanatory value for the variable Y in the model (Hair *et al.*, 1998) [12]. And if the VIF of a

variable <2 , it is assumed that multicollinearity does not occur. Actually, if $VIF >2$, we must be cautious in interpreting regression weights as such (Nguyen Dinh Tho, 2011, p. 497).

▪ **Confirmatory factor analysis CFA**

Confirmatory factor analysis CFA is the next step, according to exploratory factor analysis (EFA), including includes design to define, test, and control independently adjusts measurement models. The purpose of the CFA is to establish measurement models, a good fit, measure is used to test the model's linear structure. The result of the CFA, the test shows the overall goodness of fit of the model the criteria: Chi-square = 256.068; 146 steps due; P-value = 0.000. The criteria to measure the fit of the model is relatively high and satisfactory (TLI= 0.955 > 0.9 ; CFI = 0.962 > 0.9 ; RMSEA = 0.052 < 0.08 ; Chi - Square/df = 1.754 < 2). In addition, the scale satisfactory concepts of reliability, simplicity integer, convergent, and discriminant.

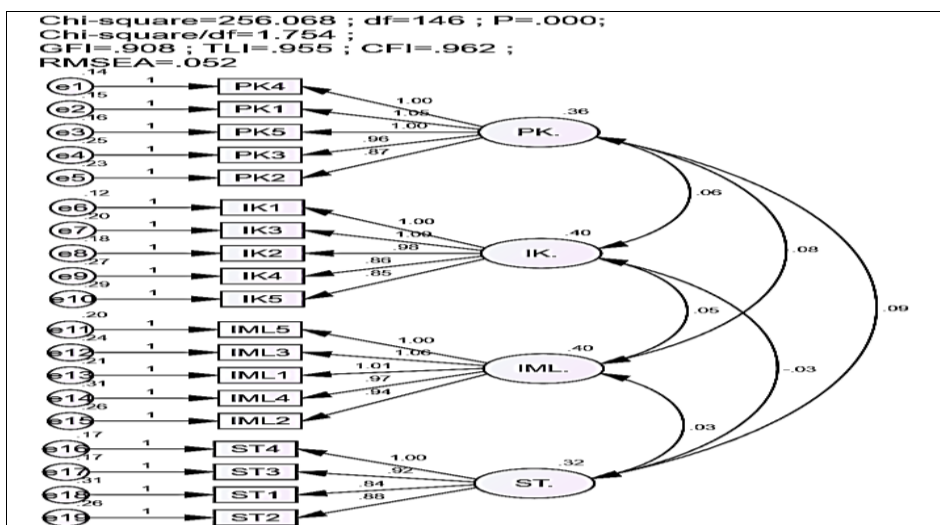

Fig 3: CFA analysis results

▪ **SEM linear structural model analysis**

The SEM linear structural model analysis method was used to test the research models. After making the model adjustment by hooking the error pairs of the pairs of measured variables' corresponding measures, the model's fit indicators are improved and met the requirements. The

results of the SEM structural model analysis are shown in Figure 4, showing that the model achieves compatibility with survey data: Chi-square = 398.185; 264 steps due; P-value = 0.000.the criteria TLI = 0.956 (≥ 0.9), CFI = 0.9362 (≥ 0.9), RMSEA = 0.042 (< 0.08), Chi-Square/df = 1.508 all met the requirements.

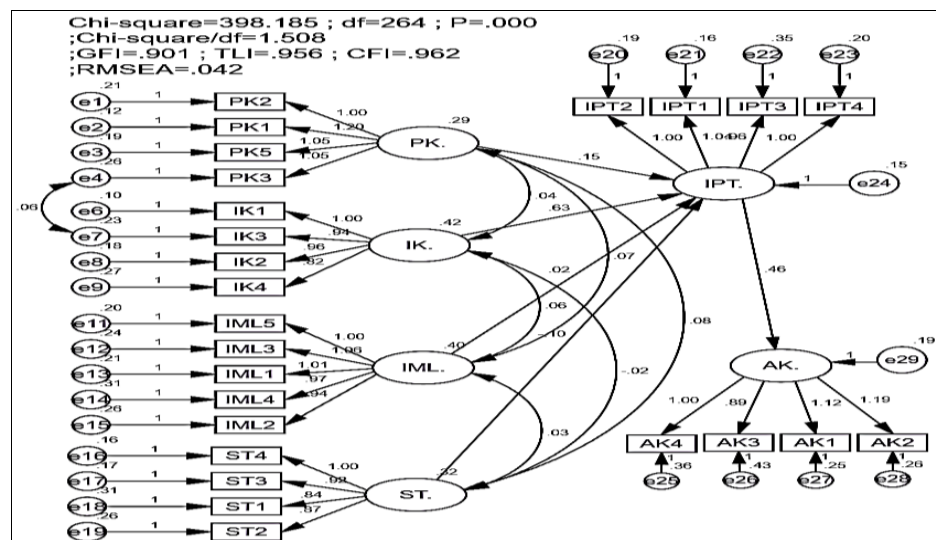

Fig 4: SEM analysis results

The author uses Lin's (2005) [18] interaction scale and Napier's (2005) [21] criteria on the diversity of interactive channels and communication levels to build a scale of the interaction of Vietnamese lecturers with partners.

- I often interact with partner lecturers (Lin, 2005) [18].
- I can interact with partner lecturers in many different ways (Napier, 2005) [21].
- I can interact with many people at different levels of teaching/management partners (Napier, 2005) [21].
- My interaction with partner trainers is sufficient for the job (Lin, 2005) [18].
- The communication atmosphere between me and my partner lecturers is very friendly (Lin, 2005) [18].
- My interactions with partner trainers are constructive (Lin, 2005) [18].

Through the exchange and explanation of partner lecturers, Vietnamese lecturers not only grasp the teaching methods - knowledge and know-how - but also understand the reasons, and the training philosophy attached to it, i.e. knowledge and understanding. Training practices associated with advanced education such as being student-centred and encouraging critical thinking are conveyed through stories, examples and explanations by foreign lecturers. While those philosophies are not mentioned directly and explicitly, if teachers recognize them, they will absorb them.

“In terms of learning”, "the best thing we can imagine is how to think about working with students, changing the way students are assessed, how to provide opportunities, and listening to students.”

Table 5: Results of testing the relationship between concepts

Parameter	Estimate	S.E.	C.R.	P	Label
IPT <--- PK	.149	.060	2.478	.013	yes
IPT <--- IK	.626	.052	12.025	***	yes
IPT <--- IML	.016	.049	.329	.042	yes
IPT <--- ST	.096	.057	1.685	.022	yes
AK <--- IPT	.456	.067	6.803	***	yes

Test the theoretical model of the Bootstrap method

The Bootstrap method is implemented with a repeated sample count of N = 1000 times. Estimates from N samples are averaged, and this value tends to be close to the population estimate. The difference between the mean of the estimates from Bootstrap and the original estimates is called the bias. The results of parameter estimation by Bootstrap are shown in Table 6.

Table 6: Results of parameter estimation using Bootstrap

Parameter	SE	SE-SE	Mean	Bias	SE-Bias	CR
IPT <--- PK	0.072	0.002	0.146	-0.003	0.002	-1.5
IPT <--- IK	0.08	0.002	0.629	0.003	0.003	1
IPT <--- IM	0.058	0.001	0.017	0.001	0.002	0.5
IPT <--- ST	0.066	0.001	-0.1	-0.004	0.002	-2
AK <--- IPT	0.081	0.002	0.453	-0.003	0.003	-1

5. Discussing quantitative research results

Basically, the test results confirm the effects of some personal factors and some social factors on the knowledge acquisition of lecturers, and at the same time confirm that social factors have a controlling relationship. details on the influence of personal factors on knowledge acquisition. The teacher's expertise has a low-level influence on knowledge acquisition. This is quite consistent with the

qualitative research results of the thesis on professional knowledge factors and in accordance with the studies of Ojo and Raman (2017) [26] and Rowold (2007) [30].

Intrinsic motivation to learn has an effect on teachers' knowledge acquisition with medium significance, consistent with theory and some previous studies (Kankanhalli *et al.*, 2012) [15]. One's intrinsic energy is a sustainable source of energy for the person to acquire knowledge, even if the benefits of learning are not anticipated (Yildiz *et al.*, 2019) [39].

Socialized thinking is the factor that affects the acquisition of knowledge and is confirmed with a very strong significance level, compared to other individual factors. The results are consistent with the theory and previous research of Lowik *et al* (2017) [19], showing the importance of thinking style to knowledge acquisition in general. In the international joint training program, the higher the socialization mindset of the lecturer, the more knowledge is received. Differences in thinking styles account for differences in information processing and decision-making (Zahra and George, 2002) [40].

The positive regulatory influence of interaction with partner lecturers on the relationship between socialized thinking and knowledge acquisition is strongly confirmed. This is consistent with the theory. The higher the interaction efficiency, the greater the influence of socializing thinking on the teacher's knowledge acquisition and vice.

Conclusion

The results of quantitative testing of the model of the influence of personal and social factors on the reception of knowledge about training by lecturers through the international training program. Confirmed relationships include:

- Positive influence of the following factors: professional knowledge, intrinsic motivation to learn, socializing thinking, interaction with partner lecturers,
- The positive regulatory influence of the interaction factor with partner lecturers on the relationship between professional knowledge and knowledge acquisition, socialization thinking and knowledge acquisition;

Thus, qualitative and quantitative research together confirm the positive influence of intrinsic learning motivation factors and interaction with partner lecturers on the reception of students' teacher training knowledge. Both studies suggest that further testing of the technical knowledge factor is warranted because the evidence for the effect is weak, possibly due to the effect of the “capacity trap”. As for the intercultural knowledge factor, the qualitative research results have not shown the variation of the factor because this factor of the lecturers is quite uniform. This assertion is reinforced when no evidence of the effect of this factor has been found in quantitative studies. The influence of the socialization thinking factor, although not confirmed in qualitative research, is confirmed with strong evidence in quantitative research, confirming hypothesis H4 that socializing thinking has a positive influence on socialization towards the teacher's reception of knowledge.

While qualitative research makes predictions about the moderating role of two factors interacting with partner lecturers to the relationship between individual factors and knowledge acquisition. Knowledge, quantitative research specifically confirms this regulatory role in the effects

between professional knowledge, intrinsic learning motivation and socialized thinking on knowledge acquisition.

References

1. Ajzen I. The Theory of Planned Behavior', *Organizational Behavior and Human Decision Processes*,1991:50(2):179-211.
2. Alavi, Leidner. Knowledge management and knowledge management systems: conceptual foundations and ssresearch iueS. *MIS Quarterly*,2001:25(1):107-136.
3. Cohen WM, Levinthal DA. Absorptive Capacity: A New Perspective on Learning and Innovation. *Administrative Science Quarterly*,1990:35(1):128-152.
4. Costa PT, McCrae RR. The five-factor model of personality and its relevance to personality disorders', *Journal of Personality Disorders*,1992:6(4):343-359.
5. Dao L, Nguyen L. Knowledge Acquisition of Local Managers: Its Antecedents and Effectiveness. *Journal of Economics and Development*,2016:18(3):64-86.
6. Dorri M, Yarmohammadian MH, Nadi MA. A review on value chain in higher education. *Procedia - Social and Behavioral Sciences*,2012:46:3842-3846.
7. Easterby-Smith M, Lyles MA, Tsang EWK. Inter-Organizational Knowledge Transfer: Current Themes and Future Prospects. *Journal of Management Studies*,2008:45(4):677-690.
8. Esmaeelinezhad O, Afrazeh A. Linking personality traits and individuals' knowledge management behavior. *Aslib Journal of Information Management*,2018:70(3):234-251.
9. Fey C, Minbaeva D, Pedersen T, Björkman I. A retrospective on: MNC knowledge transfer, subsidiary absorptive capacity and HRM. *Journal of International Business Studies*,2014:45(1):52-62.
10. Foss N. Alternative research strategies in the knowledge movement: From macro bias to micro-foundations and multi-level explanation. *European Management Review*,2009:6(1):16-28.
11. Grant RM. Toward a Knowledge-based Theory of the Firm. *Trategic Management Journal*, số 17, No. Winter Special, 1996, 109-122.
12. Hair JF, Tatham RL, Anderson RE, Black W. *Multivariate Data Analysis* (5th ed.). Prentice-Hall, Englewood Cliffs, 1998.
13. Jashapara A. *Knowledge Management: an Integrated Approach* (2nd ed.). Pearson Education Limited, England, 2011.
14. Kakabadse NK, Kakabadse A, Kouzmin A. Reviewing the knowledge management literature: towards a taxonomy. *Journal of Knowledge Management*,2003:7(4):75-91.
15. Kankanhalli A, Pee LG, Tan GW, Chhatwal S. Interaction of Individual and Social Antecedents of Learning Effectiveness: A Study in the IT Research Context. *IEEE Transactions on Engineering Management*,2012:59(1):115-128.
16. Kim S, Lee H. Factors affecting employee knowledge acquisition and application capabilities', *Asia-pacific Journal of Business Administration*,2010:2(2):133-152.
17. Ko DG, Kirsch L, King W. Antecedents of Knowledge Transfer from Consultants to Clients in Enterprise System Implementations', *MIS Quarterly*,2005:29(1):59-85.
18. Lin X. Local Partner Acquisition of Managerial Knowledge in International Joint Ventures: Focusing on Foreign Management Conppol. *Management International Review*,2005:45(2):219-237.
19. Lowik S, Kraaijenbrink J, Groen Aard J. Antecedents and effects of individual absorptive capacity: a micro-foundational perspective on open, 2017.
20. Minbaeva D, Pedersen T, Bjorkman I, Fey C, Park H. MNC knowledge ppansfer, subsidiary absorptive capacity, and HRM. *Journal of International Business Studies*,2003:34(6):586-599.
21. Napier N. Knowledge ppansfer in Vietnam: Starts, stops, and loops. *Journal of Managerial Psychology*,2005:20(7):621-636.
22. Nonaka I. A Dynamic Theory of Organizational Knowledge Creation, *Organization Science*,1994:5(1):14-37.
23. Nonaka I, Krogh GV. Tacit Knowledge and Knowledge Conversion: Conppoversy and Advancement in Organizational Knowledge Creation Theory. *OrganizationScience*,2009:20(3):635-652.
24. O'Dell C, Grayson CJ. If Only We Knew What We Know: Identification and Ppansfer of Internal Best Practices. *California Management Review*,1998:40(3):154-174.
25. OECD. *The Future of Education and Skills*, Paris, 2018.
26. Ojo A, Raman M. Individual differences and knowledge acquisition capability in joint ICT project teams in Malaysia. *International Journal of Technology, Policy and Management*,2017:17(1):70-78.
27. Park BI, Choi J. Foreign direct investment motivations and knowledge acquisition from MNEs in overseas subsidiaries. *Canadian Journal of Adminisppative Sciences*,2014:31(2):104-115.
28. Pathak V, Pathak K. Reconfiguring the higher education value chain. *Management in Education*,2010:24(4):166-171.
29. Phan Thuy Chi, Le Thi Huong Lan. The 4-stage model of international ppaining association – Formation practice and development process. Proceedings of the international scientific conference Quality and effectiveness results of international joint ppaining programs, National Economics University, Hanoi, 2017, 99-116.
30. Rowold J. Individual influences on knowledge acquisition in a call center ppaining context in Germany. *International Journal of Ppaining and Development*,2007:11(1):21-34.
31. Ryle G. The concept of mind, Huichinson, London Simon, H. A. (1991). Bounded rationality and organizational learning. *Organization Science*,1949:2(1):125-134.
32. Sison R, Pablo ZC. Value Chain Framework and Support System For Higher Education. *Proceedings ofthe Philippine Computing Science Congress*, Manila, 2000.
33. Suppino A, Pillay H. Knowledge ppansfer through a ppansnational program partnership between Indonesian and Ausppalian universities. *Asia Pacific Education Review*,2015:16(3):379-388.

34. Szulanski G. Exploring internal stickiness: Impediments to the transfer of best practice within the firm. *Strategic Management Journal*,1996;17(4):27-43.
35. Tho ND, Ppang NTM. Scientific research marketing-application of SEM. Labor Publishing House, 2011.
36. Tzortzaki AM, Mihiotis A. A Review of Knowledge Management Theory and Future Directions. *Knowledge and Process Management*,2014;21(1):29-41.
37. Van der Merwe A, Cronje J. The educational value chain as a modelling tool in re-engineering efforts. *3rd International Symposium on Information and Communication Technologies*, Nevada, 2004.
38. Vera D, Crossan M. Improvisation and Innovative Performance in Teams. *Organization Science*,2005;16(3):203–224.
39. Yildiz HE, Murtic A, Zander U, Richtnér A. What Fosters Individual-Level Absorptive Capacity in MNCs? An Extended Motivation–Ability– Opportunity Framework. *Management International Review*,2019;59(1):93- 129.
40. Zahra SA, George G. Absorptive Capacity: a Review, Reconceptualization, And Extension. *Academy of Management Review*,2002;27(2):185-203.