

## Power factor correction based BLDC motor drive

Amruta Shivaji Anuse

Department of Electrical Engineering, TSSM'S BSCOER, Savitribai Phule Pune University, Pune, Maharashtra, India

### Abstract

This paper presents power factor correction based BLDC motor drive by using bridgeless Luo converter. A voltage sensor is used for speed control of brushless DC motor. Power factor correction is implemented at AC mains. Electronic commutation is used to reduce switching losses.

The proposed BLDC motor drive is designed for a wide range of speed control. The proposed BLDC motor drive is with an improved power quality at AC mains. This power quality indices obtained is according to limits of IEC 61000-3-2.

**Keywords:** BLDC motor, electronics commutation, power quality, IEC

### 1. Introduction

Brushless direct current motors (BLDC) are one of the advance motors used which are rapidly increasing their popularity and applications. BLDC motor has rotor with permanent magnets and stator with stacked steel laminations with windings inserted in slots. The motor has less inertia, therefore easier to start and stop. BLDC motors do not have brushes (hence the name "brushless DC") and must be electronically commutated. BLDC motors are potentially cleaner, faster, more efficient, less noisy and more reliable. Generally a BLDC motor is considered to be a high performance motor i.e. capable of providing large amounts of torque over a vast speed range

In the brushless DC motor, polarity reversal is performed by power transistors switching in synchronization with the rotor position. Therefore, BLDC motors often incorporate either internal or external position sensors to sense the actual rotor position or its position can also be detected without sensors. BLDC motors are used in Automotive, Aerospace, Consumer, Medical, Industrial Automation Equipment and Instrumentation.

A conventional BLDC motor drive consists of a front end diode bridge rectifier and a high value of DC link capacitor which draws highly distorted peak current. It is rich in harmonics. Fig. 1 shows the conventional scheme of BLDC motor drive with a pulse width modulation (PWM).

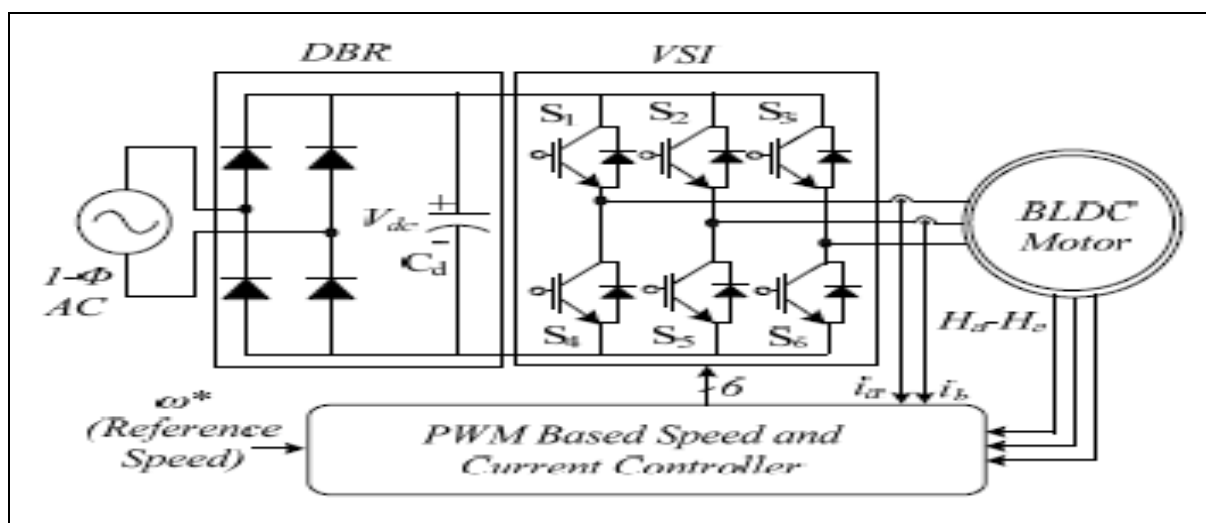

Fig 1: A conventional DBR fed BLDC motor drive.

These power quality indices are not acceptable under the limits of international power quality standards such as IEC 61000-3-2. These power quality indices also increase the EMI in the PFC converter.

The conventional boost-PFC for feeding a BLDC motor drive is as shown in fig 2. This suffers from high switching loss because of high switching frequency of PWM pulses for VSI which drastically reduces the efficiency of overall system.

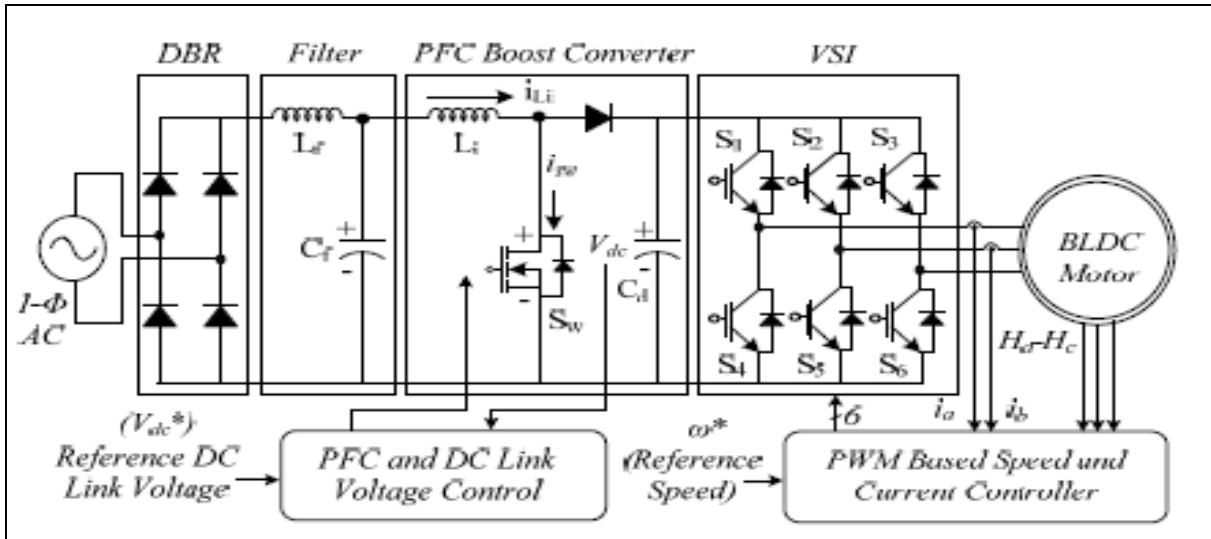

Fig 2: A conventional PFC based BLDC motor drive

**2. Proposed BLDC motor Drive**

The proposed power factor correction based BL-Luo converter is as shown in fig. 3. A proposed circuit consists of single phase supply with filter & BL-Luo converter which is used to feed voltage source inverter driving a BLDC motor. The BL-Luo converter acts as a power factor pre regulator.

Electronics commutation is used to reduce switching losses. This scheme is designed & performance is simulated for achieving an improved power quality at AC mains for wide range of speed control as well as supply voltage variations.

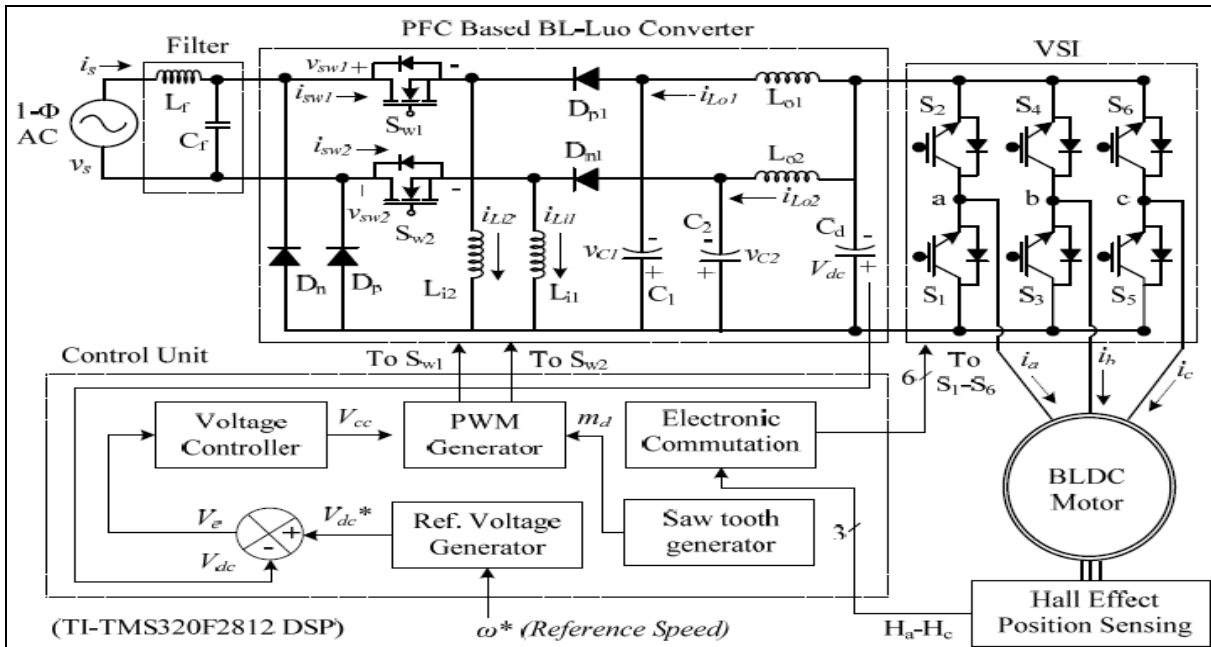

Fig 3: Proposed PFC BL-Luo Converter fed BLDC motor drive.

**3. Operation of PFC BL-LUO converter**

The operation of proposed circuit is classified into two parts that is operation during the positive and negative half cycles of supply voltage.

**1. Operation during Positive and Negative Half Cycles**

Fig. 4 shows operation of power factor correction BL-Luo converter for both positive and negative half cycles. The bridgeless converter consist of two switches operate for a positive and negative half cycles of supply voltage. Switch Sw1, inductors Li1 and Lo1 and diodes Dp and Dp1 conduct

during the positive half cycle as shown in fig. 4(a). In similar manner switch Sw2, inductors Li2 and Lo2 and diodes Dn and Dn1 conduct during the negative half cycle as shown in fig. 4(d).

**2. Operation during Complete Switching Cycle**

**Mode I:** When switch Sw1 is turned-on, the input side inductor (Li1) stores energy depending upon the current (iLi) flowing through it and the inductor value (Li1). The energy stored in intermediate capacitor (C1) is transferred to the DC link capacitor (Cd) and the output side inductor (Lo). So, the

voltage across capacitor ( $V_{C1}$ ) decreases. The current in output inductor ( $i_{Lo1}$ ) and the DC link voltage ( $V_{dc}$ ) are increased.

**Mode II:** When switch  $Sw1$  is turned-off, the input side inductor ( $Li1$ ) transfers its energy to the capacitor ( $C1$ ) through diode  $Dp1$ . So, the current  $i_{Li1}$  decreases till it reaches zero, and the voltage across capacitor ( $V_{C1}$ ) increases. The DC link capacitor ( $Cd$ ) provides the required energy to the load so the DC link voltage  $V_{dc}$  reduces in this mode.

**Mode III:** No energy is left in the input inductor ( $Li1$ ) i.e. current  $i_{Li1}$  becomes zero and enters discontinuous conduction mode of operation. The capacitor ( $C1$ ) and output inductor ( $Lo1$ ) are discharged so current  $i_{Lo1}$  and voltage  $V_{C1}$  is reduced and DC link voltage  $V_{dc}$  increases in this mode of operation.

In a similar way, for negative half cycle of supply voltage the inductor's  $Li2$  and  $Lo2$ , diode  $Dn1$  and capacitor  $C2$  conduct to achieve a desired operation.

#### 4. Results & Discussion

A power factor correction based BL-Luo converter fed BLDC motor drive is proposed for wide range of speeds as well as supply voltage. A single voltage sensor is used for speed control of BLDC motor. An electronic commutation is used which utilized for reduced switching losses.

#### 5. References

1. Yedamale P. Microchip Technology Inc, Brushless DC (BLDC) motor fundamentals. 2003, 885.
2. Singh S, Singh B. A Voltage-Controlled PFC Cuk Converter Based PMBLDCM Drive for Air-Conditioners, IEEE Trans. Ind. Appl. 2012; 48(2):832-838.
3. Singh B, Singh BN, Chandra A, Al-Haddad K, Pandey A, Kothari DP. A review of single-phase improved power quality AC-DC converters, IEEE Trans. Industrial Electron. 2003; 50(5):962-981.
4. Singh B, Singh S, Chandra A, Al-Haddad K. Comprehensive Study of Single-Phase AC-DC Power Factor Corrected Converters With High-Frequency Isolation, IEEE Trans. Ind. Informatics. 2011; 7(4):540-556.
5. Jang Y, Jovanović MM. Bridgeless High-Power-Factor Buck Converter, IEEE Trans. Power Electron. 2011; 26(2):602-611.
6. Williams B. Generation and Analysis of Canonical Switching Cell DC-to-DC Converters, IEEE Trans. Ind. Electron, 2013.