



Volume: 2, Issue: 7, 182-187
July 2015
www.allsubjectjournal.com
e-ISSN: 2349-4182
p-ISSN: 2349-5979
Impact Factor: 3.762

Vijay M Mundhe

ME Student (Computer Aided Analysis & Design), Department of Mechanical Engineering, SSVPS BSD COE Dhule, Maharashtra (424001) India.

Prof. Eknath R Deore

Head of Department, Department of Mechanical Engineering, SSVPS BSD COE Dhule, Maharashtra (424001) India.

Design and analysis of perforated muffler in Automobile Exhaust System

Vijay M Mundhe, Eknath R Deore

Abstract

A muffler is an important part of an engine system used in exhaust system to reduce exhaust gas noise level. The literature review reveals that the exhaust gas noise level depends upon various factors. Muffler geometry, extension in inlet and outlet valves, number of whole perforations and its diameter are the factors which affects noise from engines. The objective of this study is to reduce exhaust gas noise level. The performance of the muffler is assessed by analyzing pressure variation, exhaust gas flow pattern, length of expansion chamber, transmission loss. The K-epsilon method is used to obtain desired outputs by inputting sinusoidal nature of pressure wave. The modeling of muffler is done by using modeling software CATIA V5 and performance parameters are estimated using Star CCM+ software. This study helps to improve reduce the noise level and environmental noise pollution. The results obtained from software are compared with analytical method and they are found close agreement with each other.

Keywords: Back Pressure, Expansion Chamber, Flow Pattern, Insertion Loss, Mach number, Muffler, Transmission loss.

1. Introduction

The purpose of an automotive muffler is to reduce engine noise emission. If vehicles did not have a muffler there would be an unbearable amount of engine exhaust noise in our environment. Noise is defined as unwanted sound. All noise emitted by an automobile does not come from the exhaust system. Other contributors to vehicle noise emission include intake noise, mechanical noise and vibration induced noise from the engine body and transmission.

The automotive muffler has to be able to allow the passage of exhaust gasses whilst restricting the transmission of sound. To examine the performance of any muffler, certain parameters are used. These parameters are transmission loss and insertion loss. The transmission loss gives a value in decibel (dB) that corresponds to the ability of the muffler to dampen the noise. Transmission loss is independent from the noise source, thus this property of muffler does not vary with respect to noise source generally, engines produce noise of 100 to 130 dB depending on the size and the type of the engine. In this study, acoustic and flow characteristic of a perforated reactive muffler were analyzed.

Yunshi Yao has done work on optimal design and the test on a reactive muffler of a vibratory roller based on the CFD and experimental study ^[1]. Potente Daniel has studied on principal of muffler design and advantages of various types of muffler has discussed for designing purpose ^[2]. K. Suganeswaran has done work on Design and modification of muffler is important to achieve back pressure and attenuation. Target value which is compromise between transmission loss and backpressure, is set for initial stage and to achieve target value internal structure is modified ^[3]. M. Rahman makes muffler for stationary petrol engine has been designed and manufactured. The performance characteristics, i.e. noise reduction capability of the muffler, has been tested and compared with that of the conventional muffler ^[4]. Shitalkumar Ramesh Shah has gives idea in paper on how modern CAE tools could be useful for optimizing overall system design balancing parameters like noise and transmission loss ^[5].

2 Types of muffler

There are two main types of muffler designs commonly used,

- 2.1 Reactive or Reflective muffler
- 2.2 Absorptive or Dissipative muffler

2.1. The Reactive or Reflective Muffler

It use the phenomenon of destructive interference to reduce noise. This means that they are designed so that the sound waves produced by an engine partially cancel themselves out in the

Correspondence:

Vijay M Mundhe

ME Student (Computer Aided Analysis & Design), Department of Mechanical Engineering, SSVPS BSD COE Dhule, Maharashtra (424001) India.

muffler. For complete destructive interference to occur a reflected pressure wave of equal amplitude and 180 degrees out of phase needs to collide with the transmitted pressure wave. Reflections occur where there is a change in geometry or an area discontinuity.

A reactive muffler, as shown in Figure 1, generally consists of a series of resonating and expansion chambers that are designed to reduce the sound pressure level at certain frequencies. The inlet and outlet tubes are generally offset and have perforations that allow sound pulses to scatter out in numerous directions inside a chamber resulting in destructive interference.

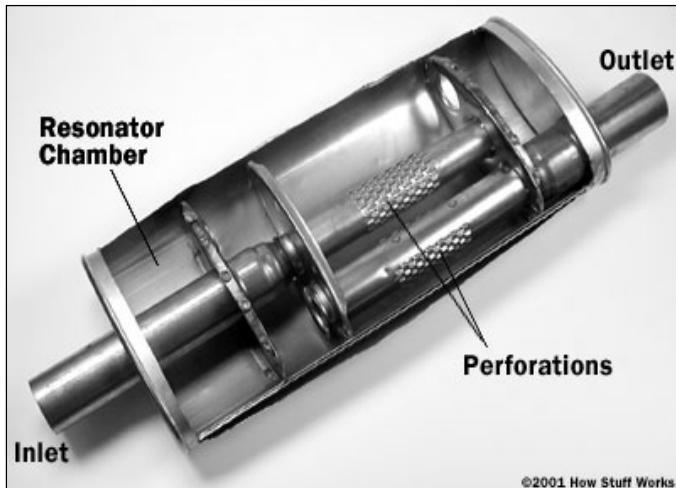

Fig 1: Typical reactive automotive muffler

2.2 An Absorptive or Dissipative Muffler

As shown in Figure 2, uses absorption to reduce sound energy. Sound waves are reduced as their energy is converted into heat in the absorptive material. A typical absorptive muffler consists of a straight, circular and perforated pipe that is encased in a larger steel housing. Between the perforated pipe and the casing is a layer of sound absorptive material that absorbs some of the pressure pulses.

Absorptive mufflers create less backpressure than reactive mufflers, however they do not reduce noise as well.

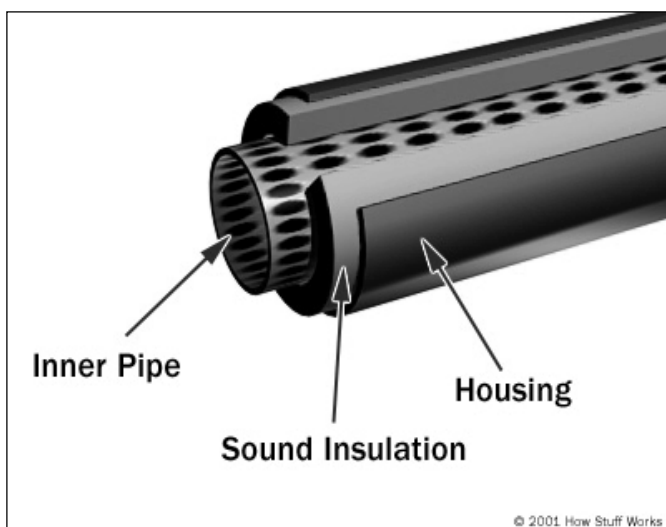

Fig 2: Typical absorptive automotive muffler

3. Functional Requirements of Exhaust Muffler

There are numerous functional requirements that should be considered when designing a muffler for a specific application. Such functional requirements may include

adequate insertion loss, transmission loss, backpressure, size, durability, desired sound, cost, shape and style. These functional requirements are detailed below focusing on an automotive muffler's functional requirements.

3.1 Adequate Insertion Loss

The main function of a muffler is to “muffle” or attenuate sound. An effective muffler will reduce the sound pressure of the noise source to the required level.

A muffler's performance or attenuating capability is generally defined in terms of insertion loss or transmission loss. Insertion loss is defined as the difference between the acoustic power radiated without and with a muffler fitted. The transmission loss is defined as the difference (in decibels) between the sound power incident at the entry to the muffler to that transmitted by the muffler. The muffler designer must determine the required insertion loss so that a suitable style of muffler can be designed for the specific purpose.

3.2. Transmission Loss

Transmission loss is a characteristic parameter which shows the performance of muffler. Selection of suitable muffler is based on transmission loss because transmission loss does not depend on the source of noise. Graph is plotted for frequency versus transmission loss. Transmission loss is vary w.r.t. change in geometry parameters such as number of holes, diameter of pipe, number of pipes.

3.3. Backpressure

Backpressure represents the extra static pressure exerted by the muffler on the engine through the restriction in flow of exhaust gasses.

Generally the better a muffler is at attenuating sound the more backpressure is generated. In a reactive muffler where good attenuation is achieved the exhaust gasses are forced to pass through numerous geometry changes and a fair amount of backpressure may be generated, which reduces the power output of the engine. Backpressure should be kept to a minimum to avoid power losses especially for performance vehicles where performance is paramount.

Every time the exhaust gasses are forced to change direction additional backpressure is created. Therefore to limit backpressure geometric changes are to be kept to a minimum, a typical example of this is a “straight through” absorption silencer. Exhaust gasses are allowed to pass virtually unimpeded through the straight perforated pipe.

3.4. Size

The available space has a great influence on the size and therefore type of muffler that may be used. A muffler may have its geometry designed for optimum attenuation however if it does not meet the space constraints, it is useless.

Generally the larger a muffler is, the more it weighs and the more it costs to manufacture. For a performance vehicle every gram saved is crucial to its performance/acceleration, especially when dealing with light open wheeled race vehicles. Therefore a small light weight muffler is desirable.

3.5. Desired Sound

Generally a muffler is used to reduce the sound of a combustion engine to a desired level that provides comfort for the driver and passengers of the vehicle as well as minimizing sound pollution to the environment. Muffler designs generally aim to reduce any annoying characteristics of the untreated exhaust noise such as low frequency rumble.

4. Methodology

To estimate performance parameters i.e. transmission loss, pressure variation, flow pattern CAD model is created in

CATIA to carry out analysis in star CCM+ software. CAD model is import in Star CCM+ software and trimmer meshing is applied on that model.

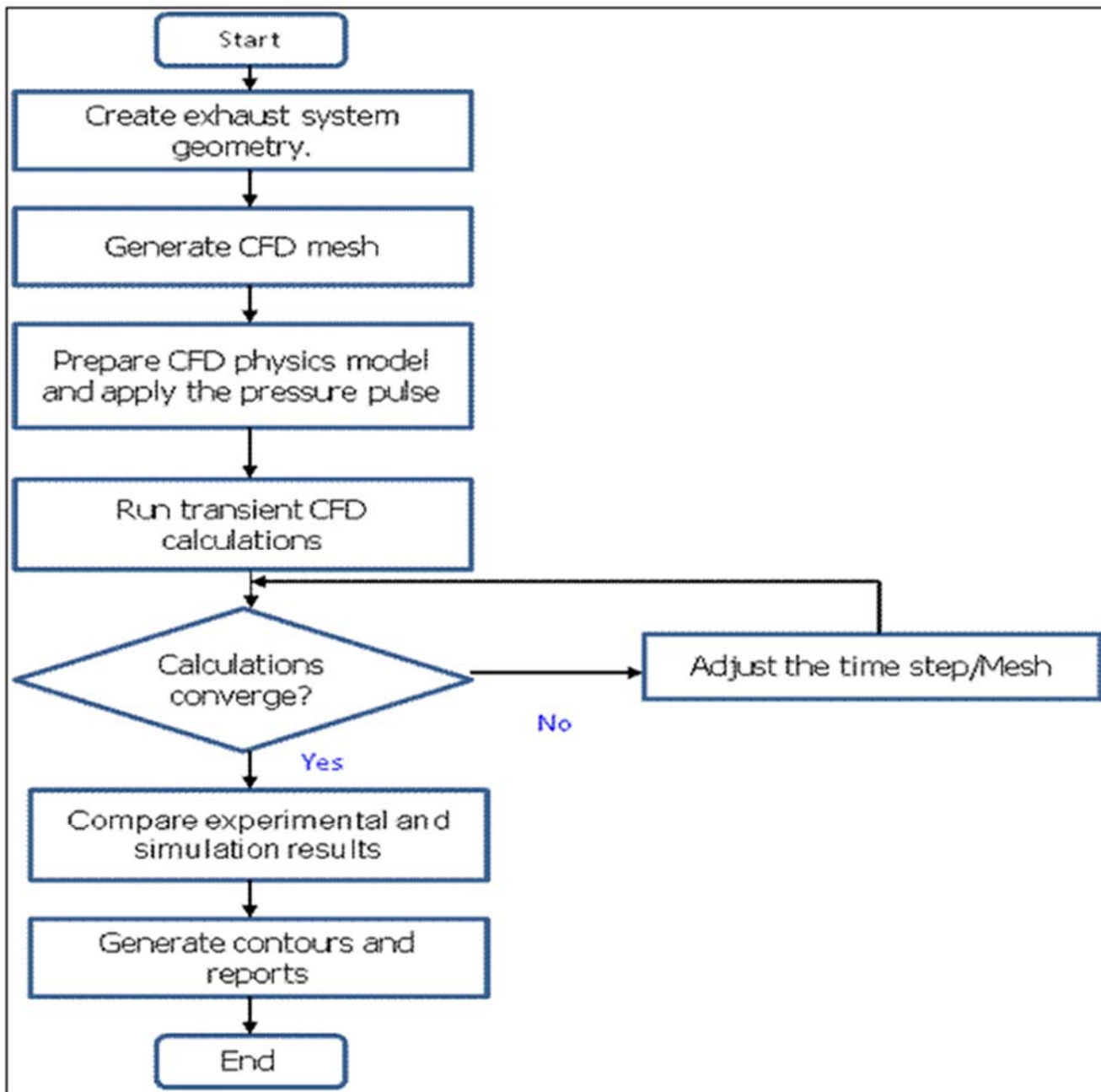

Fig 3: Flow chart

5. Model Building

Solid model of muffler is created by using CATIA V5 software. Total length of geometry of muffler is 450 mm. It has baffle1 with holes on it and baffle2, also pipes has perforations on it.

Specifications used for the model

Minor Diameter: 105mm

Major Diameter: 185 mm

Total Length: 450 mm

The muffler model is constructed using these parameters and using the Part Environment in CATIA V5.

Fig.4 and Fig.5 shows two different types of geometries used for the construction of the model. In fig.1 there are two holes on the baffle plate while in the case of Fig.5 there are four holes on the baffle plate. These two geometries are compared in every aspects for the further testing and best geometry is selected amongst two.

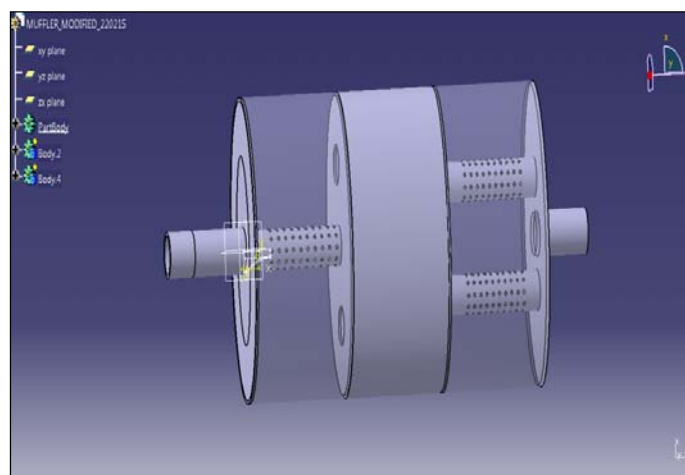

Fig 4: 3D CAD model of reactive muffler (Geometry -1)

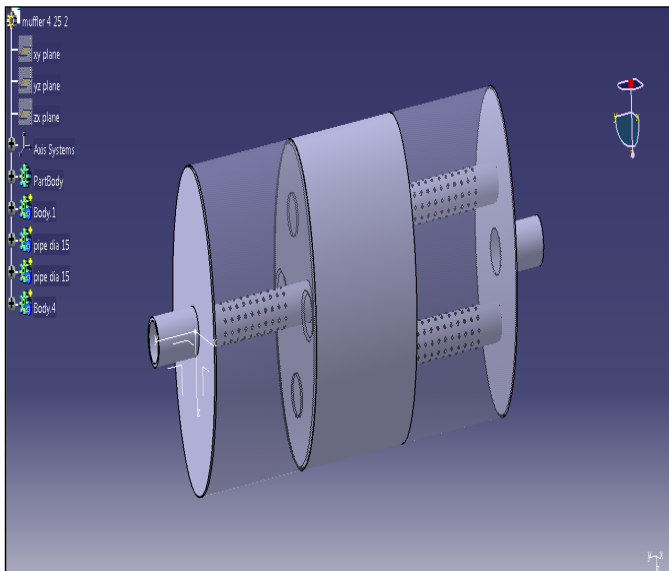

Fig 5: 3D CAD model of reactive muffler (Geometry -2)

6. Computational Meshing

In this study, the exhaust system was modelled from the tail pipe to model the exhaust system as closely as possible. The three dimensional wireframe CAD modelling data were imported in an STL format. Geometry of muffler is divided into some regions for better meshing. Trimmer meshing type is used to create the volumes in the exhaust system. The fluid domain is meshed with an average size of 5 mm. Mufflers are meshed with fine mesh size using volume controls methodology in Star CCM+.

The 3D meshing model is as shown in fig.6.

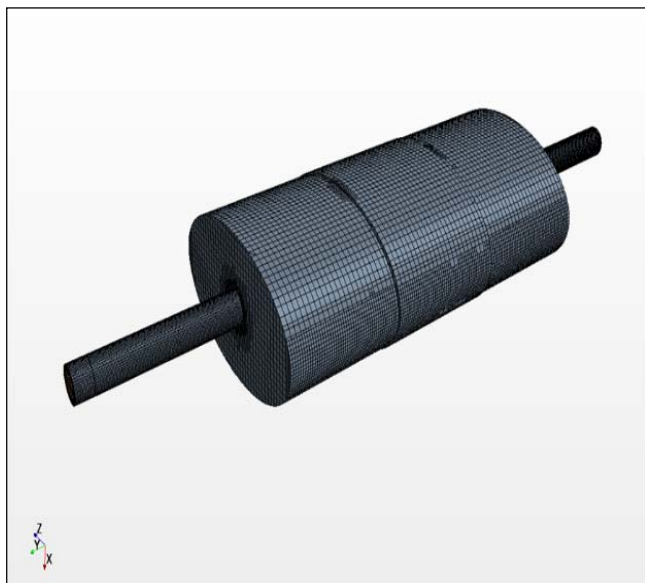

Fig 6: Mesh model

7. Initial and Boundary Conditions

Explicit unsteady model is used to solve the solution. It gives the state of model at later time from state of model at present time. Free stream type of air is selected at inlet and outlet part of muffler. Boundary condition is selected as wall for geometry.

8. Mach Number

Mach number is the ratio of velocity of medium to the velocity of sound in that medium. Fig.7 shows the velocity distribution of exhaust gas inside the muffler.

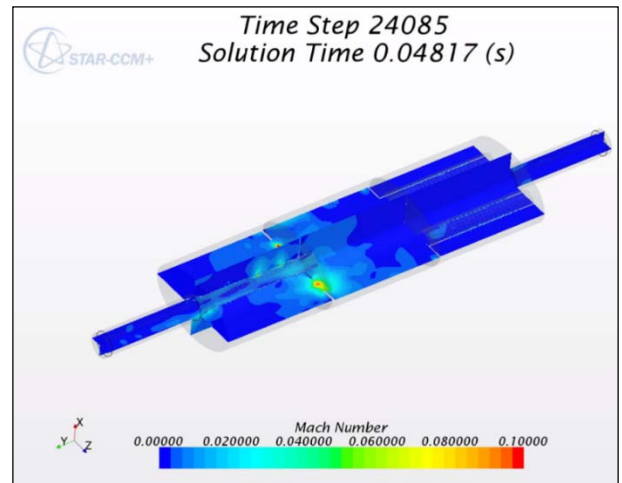

Fig 7: Velocity distribution inside the muffler

9. Turbulent Model

All physical phenomena involved in the exhaust flow are highly coupled with the turbulent flow nature of very fast change of turbulent kinetic energy generation and dissipated energy. Therefore, it is very significant to select suitable turbulence model for the simulation of the flow patterns in exhaust system. In the current study K-epsilon all Y+ model is used. Navier- Stokes equation is used for solution.

10. Comparison of Transmission Loss

Comparison of two geometries shown in figure. It shows that transmission loss of geometry is more than geometry-2, so it is preferable geometry.

For the comparison, red colour is used for the geometry -2 and blue colour is used for the geometry-1. For the particular frequency range, it is found that transmission loss of geometry is more than geometry-2, so it is preferable geometry.

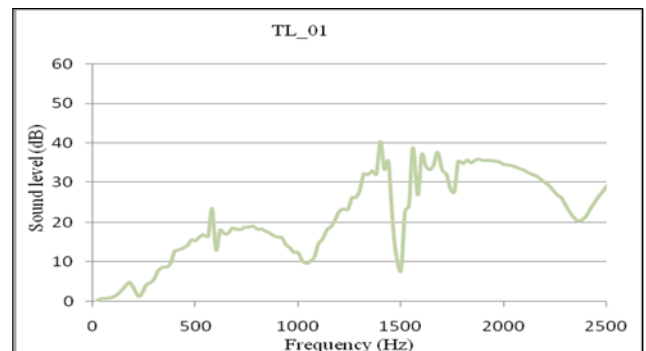

Fig 8: Transmission loss of Geometry-1

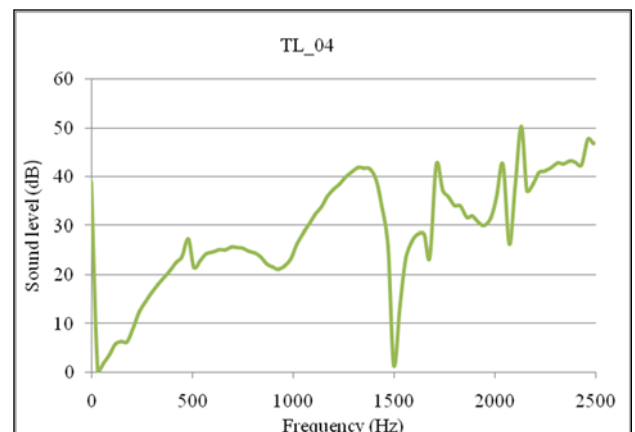

Fig 9: Transmission loss of Geometry-2

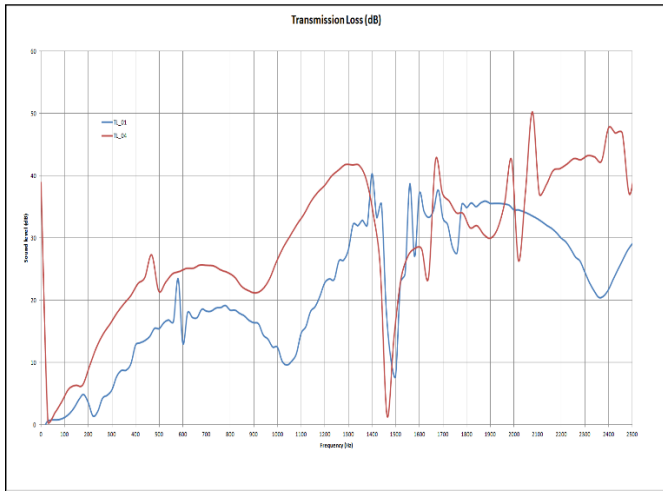

Fig 10: Comparison of transmission loss between both geometries.

11. Mass Flow Rate

Fig.11 shows the mass flow rate of the gases when we are using the geometry-1. It is found that the mass flow rate and the back pressure are the two interrelated parameters. When the mass flow rate is less the back pressure is more and when the mass flow rate is more the back pressure is less offered. This graphs are plotted for both geometries.

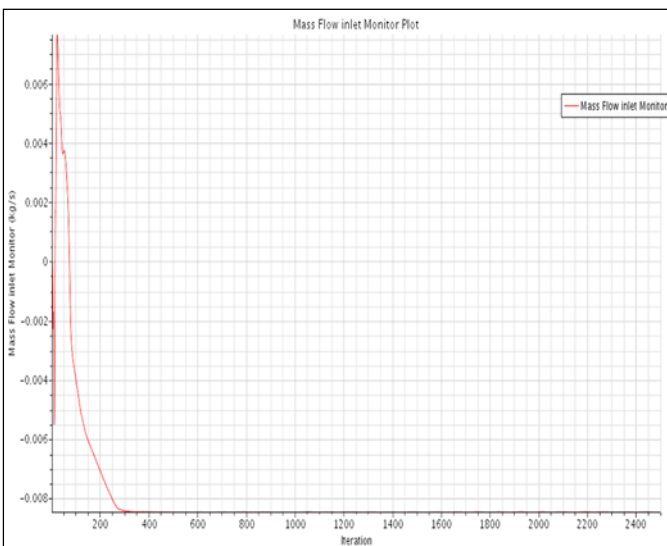

Fig 11: Mass flow rate of Geometry-1

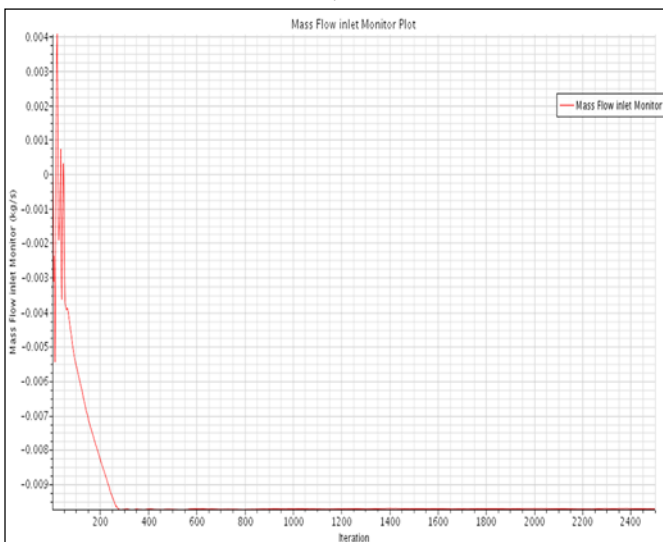

Fig 12: Mass flow rate of Geometry-2

12. Velocity Streamlines and Velocity Contours

12.1. Velocity Streamlines for Geometry-1

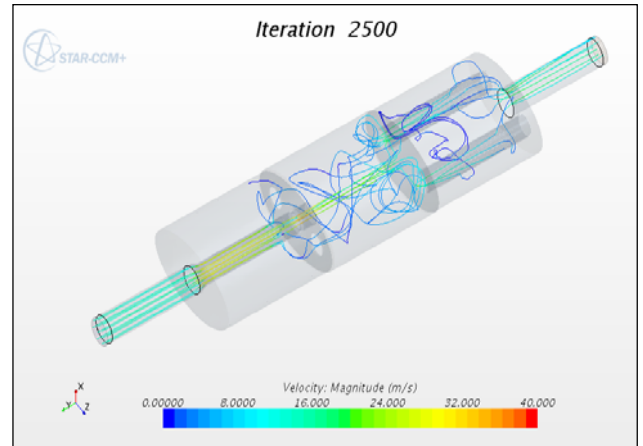

Fig 13: Velocity Streamlines for Geometry-1

Velocity streamlines shows the flow of the gases inside the muffler chamber. These are different for the two geometries and as shown in the fig.13 and fig.15 respectively for the geometry-1 and geometry-2.

12.2. Velocity contours for the geometry-1

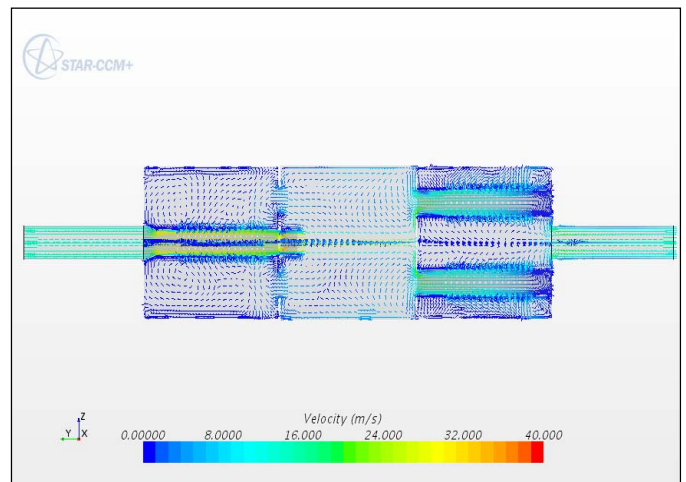

Fig 14: Velocity Contours for Geometry-1

12.3. Velocity Streamlines for Geometry2

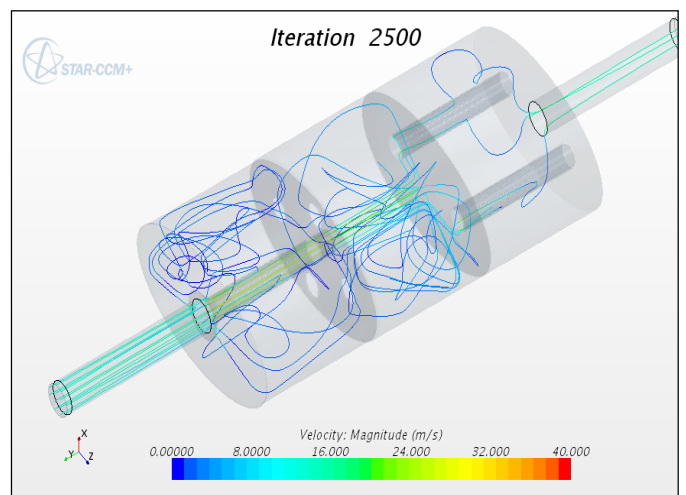

Fig 15: Velocity Streamlines for Geometry-2

12.4. Velocity contours for the geometry-2

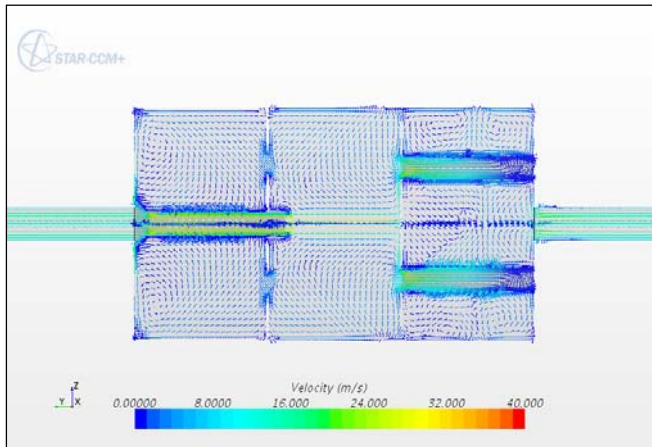

Fig 16: Velocity contours for the Geometry-2

11. Conclusion

Analysis of the process has led to two conclusions,

I. It is observed that when flow is bifurcated in third chamber number of increase in perforations causes more transmission loss.

II. Transmission loss of first geometry is more than other.

Lastly, it should be mentioned that the effect of various material combinations for muffler are not examined here.

12. Acknowledgment

Thanks to Prof. E. R. Deore, (Head of Mechanical Engineering Department, SSVPS College of Engineering, Dhule) for his valuable contribution in developing the IJMERR article template.

13. References

- 1 Yunshi Yao, Shaodong Wei, Jinpeng Zhao, Shibin Chen, Zhongxu Feng Jinxi Yue. Experiment and CFD Analysis of Reactive Muffler Research Journal of Applied Sciences, Engineering and Technology, 3282-3288, 2013
- 2 Potente, Daniel "General Design Principles for an Automotive Muffler" in Proceedings of ACOUSTICS November 2005, pp 9-11.
- 3 K.Suganeswaran, Dr. R.Parameshwaran, S.Amirthamani, D.Palanimohan "Design and Optimization of Muffler for Manufacturing" International Journal of Innovative Research in Science, Engineering and Technology, Volume 3, Special Issue 4, April 2014.
- 4 M. Rahman, T. Sharmin, A F M E. Hassan, and M. Al Nur, "Design And Construction Of A Muffler For Engine Exhaust Noise Reduction" in proceedings of the International Conference on Mechanical Engineering 2005 December 2005, 28- 30.
- 5 Shital Shah, Saisankaranarayana K, Kalyankumar S. Hatti, Prof. D. G.Thombare, "A Practical Approach towards Muffler Design, Development and Prototype Validation" SAE International 2010.